

PRODUCT INFO

Base linear unit connectors BE.E of precision-cast stainless steel have a slitted bore machined by cutting methods and are fitted with a sliding insert. This is arranged perpendicular to the face of the flange.

Together with the guide tube of the linear unit, the guide element bore forms a solid linear round guide mechanism that can be adjusted and clamped for low play. Drive keys transmit the linear movement of the linear unit to the linear unit connector.

Depending on the design, the part to be moved is fastened to the guide element or the guide element itself is installed at the place of use such that the entire linear unit moves together. At the screw point, a carriage bolt and a cap nut or an adjustable hand lever reduces the size of the guide element bore or clamping point. Type B is equipped with seals at the screw point.

Adjustable hand levers are intended for repeated, tool-free clamping. Under the designation HEK, these are available separately for individual use and in other designs. Compared with the tool-operated hex socket cap screw, the clamping force achievable with an adjustable hand lever is lower due to the shorter lever length.

RoHS-compliant product

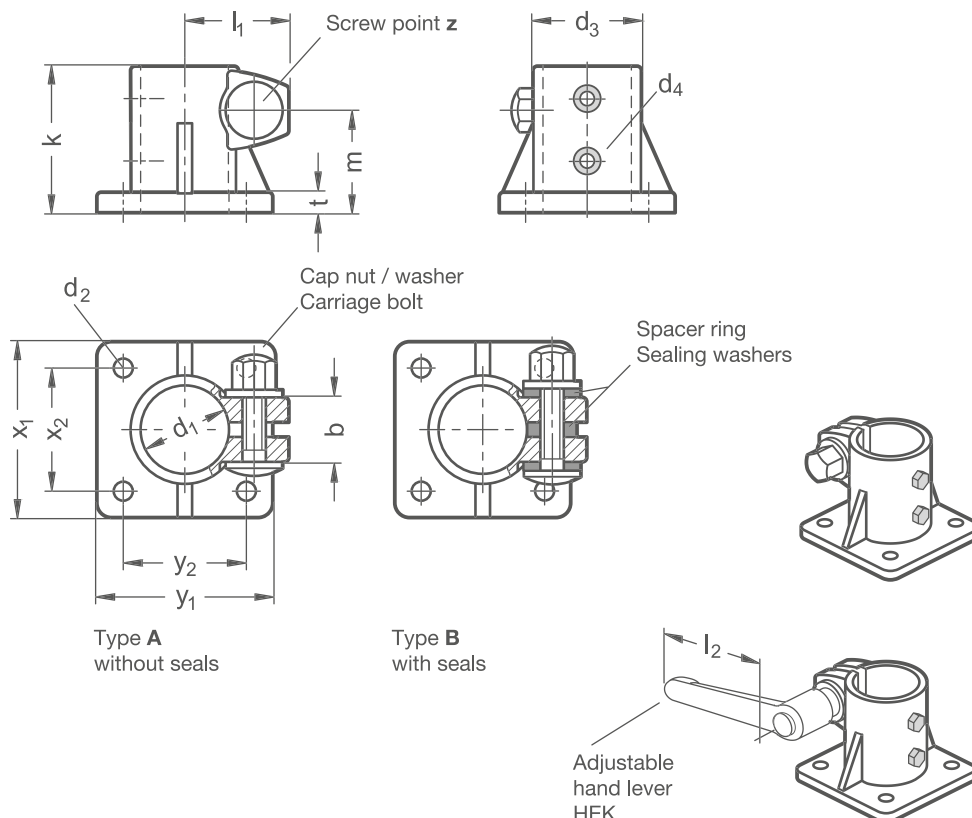

Clamping point															Accessories recom. hand lever
Bore d₁ With PTFE sliding insert	b	d₂	d₃	Mounting screws on the drive key d₄	Clamping length k	l₁	m	t	x₁	x₂	y₁	y₂	Cap nut	HEK for z lever length l₂	
G 30	22	6,5	37	M 4	50	36	35	6,5	60	42	60	42	M 8	78	
G 50	30	10,7	60	M 6	85	48,5	60	9	105	74	105	74	M 10	92	

Type t	
A	Without seals
B	With seals (sealing washer polyacetal POM, blue, spacer ring silicone 40 ... 60 Shore A, blue)

Screw point z	
4	Cap nut stainless steel DIN 917-A2 and carriage bolt stainless steel DIN 603-A2

ORDER KEY

BE.E - d₁ - t - z



ACCESSORIES

– Stainless steel adjustable hand levers **HEK** see page 170

2D
2C
2B
2A
1D
1C
1B
1A