

PRODUCT INFO

Base clamps BK of die-cast aluminum or precision-cast stainless steel have a slitted clamping point machined by cutting methods.

The base flange with four bores serves as an interface or for fastening the clamp to the place of use.

The bore at the clamping point is arranged perpendicular to the face of the flange. It receives typically available rods and tubes with full surface contact over the entire cross-section of the bore.

At the screw point, a hex socket cap screw reduces the bore cross-section for clamping.

RoHS-compliant product

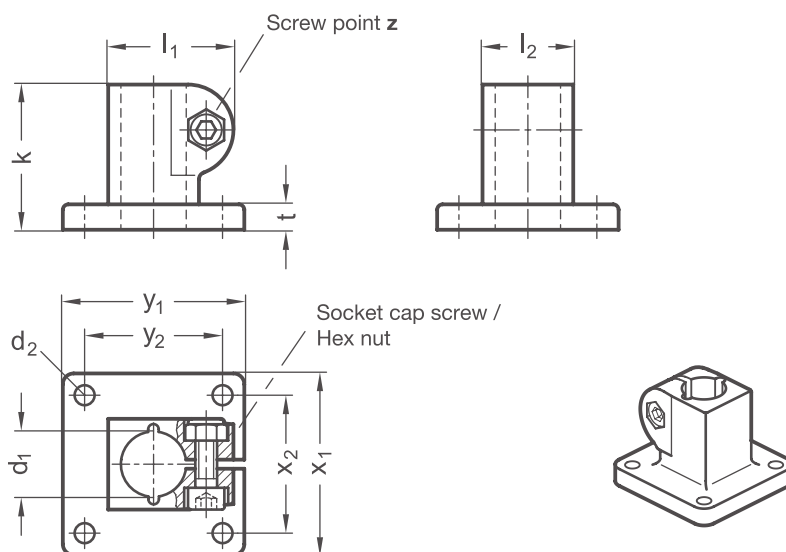

Clamping point		d ₂	Clamping length k	l ₁	l ₂	t	x ₁	x ₂	y ₁	y ₂	Hex socket cap screw
Bore d ₁											
Aluminum	Stainless steel										
B 10	-	5,5	40	34,5	25	7	50	38	50	38	M 6-20
B 12	B 12	5,5	40	34,5	25	7	50	38	50	38	M 6-20
B 14	B 14	5,5	40	34,5	25	7	50	38	50	38	M 6-20
B 15	B 15	5,5	40	34,5	25	7	50	38	50	38	M 6-20
B 16	B 16	5,5	40	34,5	25	7	50	38	50	38	M 6-20
B 18	B 18	5,5	40	34,5	25	7	50	38	50	38	M 6-20
-	B 20	5,5	40	34,5	25	7	50	38	50	38	M 6-20

Screw point z	
1	Hex socket cap screw steel, zinc-plated DIN 912-8.8 and lock nut steel DIN 985-8, zinc-plated (only for Aluminum clamps)
2	Hex socket cap screw Stainless steel DIN 912-A2-70 and lock nut Stainless steel DIN 985-A2, glide coating

Surface / material o	
2	Aluminum, textured powder-coated, Black RAL 9005
8	Aluminum, blasted, matt
ED	Stainless steel, blasted, matt

ORDER KEY

BK - d₁ - z - o

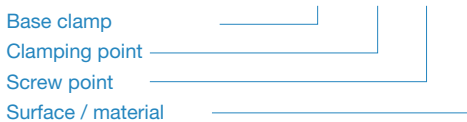

ON REQUEST

- Clamping point with special diameter
- Screw point with hex head screw
- Surface ball-burnished, anodized or powder-coated in other RAL colors

2D
2C
2B
2A
1D
1C
1B
1A