

PRODUCT INFO

T-clamps TMD of die-cast aluminum have split clamping points with identical round or square cross-section that have been partially machined by cutting methods.

The bores at the clamping points are situated in a plane and arranged in a T-shape. They receive typically available construction tubes via multiple ribs in the cross-section of the bores.

At the screw points, hex socket cap screws or adjustable hand levers reduce the bore cross-section for clamping. The clamping points are clamped simultaneously.

Adjustable hand levers are intended for repeated, tool-free clamping. Under the designation HSK, these are available separately for individual use and in other designs. Compared with the tool-operated hex socket cap screw, the clamping force achievable with an adjustable hand lever is lower due to the shorter lever length.

RoHS-compliant product

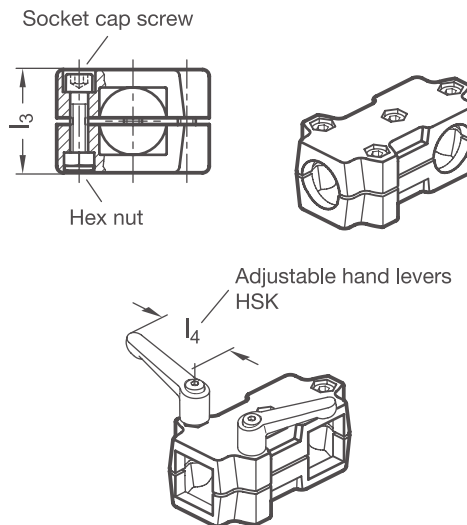
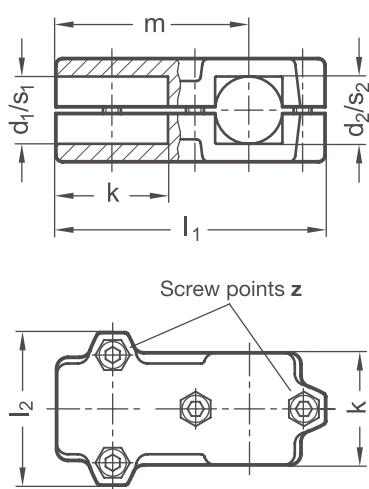
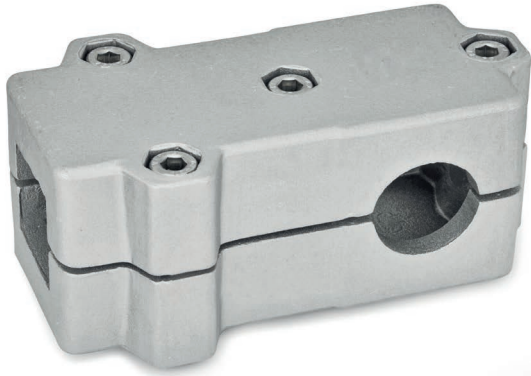

Clamping point 1		Clamping point 2		Clamping length k	l₁	l₂	l₃	m	Hex socket cap screws	Accessories recom. hand lever
Bore d₁	Square s₁	Bore d₂	Square s₂							HSK for z lever length l₄
B 20	V 20	B 20	V 20	50	120	68	46	86	M 8-35	78
B 25	V 25	B 25	V 25	50	120	68	46	86	M 8-35	78
B 30	V 30	B 30	V 30	50	120	68	46	86	M 8-35	78
B 30	V 30	B 30	V 30	60	141	79	59	101,5	M 8-50	78
B 32	-	B 32	-	60	141	79	59	101,5	M 8-50	78
B 35	V 35	B 35	V 35	60	141	79	59	101,5	M 8-50	78
B 40	V 40	B 40	V 40	60	141	79	59	101,5	M 8-50	78
B 40	V 40	B 40	V 40	76	176	98	70	127	M 10-60	92
B 42	-	B 42	-	76	176	98	70	127	M 10-60	92
B 45	V 45	B 45	V 45	76	176	98	70	127	M 10-60	92
B 48	-	B 48	-	76	176	98	70	127	M 10-60	92
B 50	V 50	B 50	V 50	76	176	98	70	127	M 10-60	92

Screw points

Z	
1	Hex socket cap screw steel, zinc-plated DIN 912-8.8 and lock nut steel DIN 985-8, zinc-plated
2	Hex socket cap screw stainless steel DIN 912-A2-70 and lock nut stainless steel DIN 985-A2, glide coating

Surface

O	
2	textured powder-coated, Black RAL 9005
8	blasted, matt

ORDER KEY

TMD - d₁/s₁ - d₂/s₂ - k - z - o

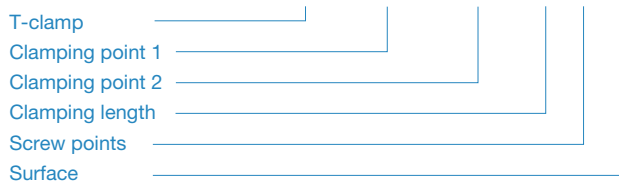

ACCESSORIES

- Adjustable hand levers **HSK** see page 168

ON REQUEST

- Clamping points with different diameters d₁, d₂, s₁ and s₂ or special diameters
- Screw points with hex head screws or mixed screw / adjustable hand lever elements
- Surface ball-burnished, anodized or powder-coated in other RAL colors

2D
2C
2B
2A
1D
1C
1B
1A