

PRODUCT INFO

Base clamps BML of die-cast aluminum have a split clamping point with round or square cross-section that has been partially machined by cutting methods.

The bore at the clamping point is arranged perpendicular to the face of the flange. It receives typically available construction tubes via multiple ribs in the cross-section of the bore.

At the screw points, hex socket cap screws or adjustable hand levers reduce the bore cross-section for clamping.

Adjustable hand levers are intended for repeated, tool-free clamping. Under the designation HSK, these are available separately for individual use and in other designs. Compared with the tool-operated hex socket cap screw, the clamping force achievable with an adjustable hand lever is lower due to the shorter lever length.

RoHS-compliant product

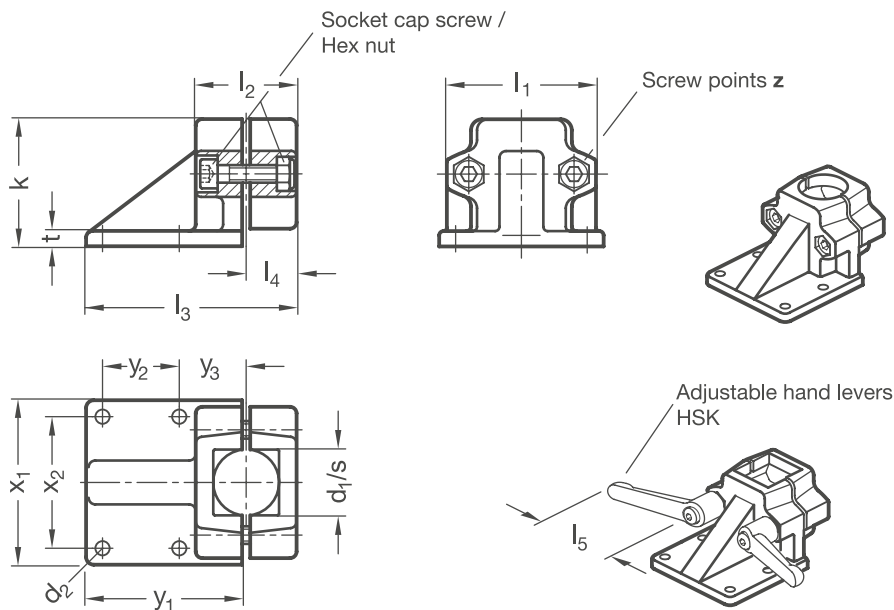
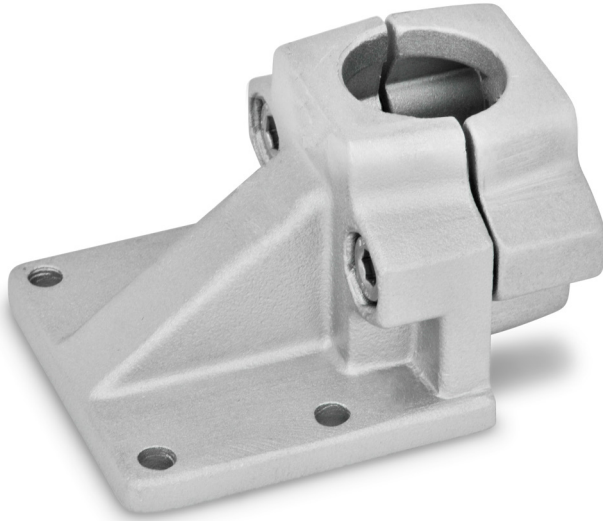

Clamping point		d ₂	Clamping length k	l ₁	l ₂	l ₃	l ₄	t	x ₁	x ₂	y ₁	y ₂	y ₃	Hex socket cap screws	Accessories recom. hand lever
Bore d ₁	Square s														HSK for z lever length l ₅
B 20	V 20	7	58	69	46	96	23	7	75	60	72	35	30	M 8-35	78
B 25	V 25	7	58	69	46	96	23	7	75	60	72	35	30	M 8-35	78
B 30	V 30	7	58	69	46	96	23	7	75	60	72	35	30	M 8-35	78
B 40	V 40	11	91	98	70	145	35	14	115	90	108	50	45	M 10-60	92
B 42	-	11	91	98	70	145	35	14	115	90	108	50	45	M 10-60	92
B 45	V 45	11	91	98	70	145	35	14	115	90	108	50	45	M 10-60	92
B 48	-	11	91	98	70	145	35	14	115	90	108	50	45	M 10-60	92
B 50	V 50	11	91	98	70	145	35	14	115	90	108	50	45	M 10-60	92
B 60	V 60	11	100	108,5	83	172	42	14	125	100	128	52	65,5	M 10-70	-

Screw points

Z

1	Hex socket cap screw steel, zinc-plated DIN 912-8.8 and lock nut steel DIN 985-8, zinc-plated
2	Hex socket cap screw stainless steel DIN 912-A2-70 and lock nut stainless steel DIN 985-A2, glide coating

Surface

O

2	textured powder-coated, Black RAL 9005
8	blasted, matt

ORDER KEY

BML - d₁ / s - z - o

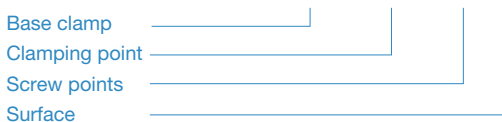

ACCESSORIES

- Adjustable hand levers **HSK** see page 168

ON REQUEST

- Clamping point with special diameter

- Screw points with hex head screws or mixed screw / adjustable hand lever elements

- Surface ball-burnished, anodized or powder-coated in other RAL colors