



PRODUCT INFO

Flanged clamps FE of matt blasted precision-cast stainless steel have a slitted clamping point machined by cutting methods.

The flange with four bores serves as an interface or for fastening the clamp to the place of use.

The bore at the clamping point is arranged in the plane parallel to the face of the flange. It receives typically available construction tubes with full surface contact over the entire cross-section of the bore.

At the screw point, a carriage bolt and a cap nut or an adjustable hand lever reduces the bore cross-section for clamping. Type B is equipped with seals at the screw point.

Adjustable hand levers are intended for repeated, tool-free clamping. Under the designation HEK, these are available separately for individual use and in other designs. Compared with the tool-operated hex socket cap screw, the clamping force achievable with an adjustable hand lever is lower due to the shorter lever length.

RoHS-compliant product

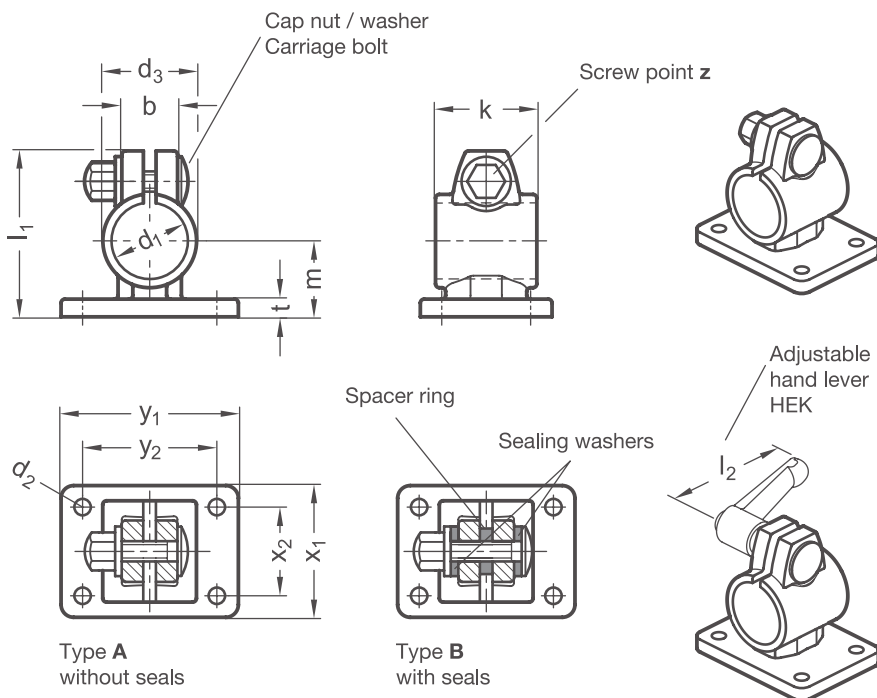

Clamping point													Accessories recom. hand lever
Bore d_1	b	d_2	d_3	Clamping length k	l_1	m	t	x_1	x_2	y_1	y_2	Cap nut	HEK for z lever length l_2
B 30	22	6,5	37	40	66	30	7	52	35	70	53	M 8	78
B 40	28	8,5	50,2	56	86	42	7,63	78	52	108	82	M 10	92
B 50	30	10,7	60	65	98,5	50	9	92	62	128	98	M 10	92

Type t	
A	Without seals
B	With seals (sealing washer polyacetal POM, blue, spacer ring silicone 40 ... 60 Shore A, blue)

Screw point z	
4	Cap nut stainless steel DIN 917-A2 and carriage bolt stainless steel DIN 603-A2

ORDER KEY

FE - d_1 - t - z

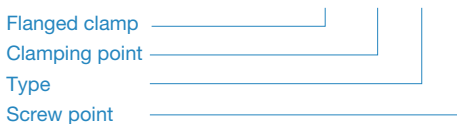

ACCESSORIES

– Stainless steel adjustable hand levers **HEK** see page 170

ON REQUEST

- Clamping point with special diameter
- Screw point with hex head screw

2D
2C
2B
2A
1D
1C
1B
1A