

PRODUCT INFO

Cross clamps KMU of die-cast aluminum have split clamping points with different round or square cross-section that have been partially machined by cutting methods.

The bores of the clamping points are offset in the plane and arranged at an angle of 90°. They receive typically available construction tubes via multiple ribs in the cross-section of the bores.

At the screw points, hex socket cap screws or adjustable hand levers reduce the bore cross-section for clamping.

Adjustable hand levers are intended for repeated, tool-free clamping. Under the designation HSK, these are available separately for individual use and in other designs. Compared with the tool-operated hex socket cap screw, the clamping force achievable with an adjustable hand lever is lower due to the shorter lever length.

RoHS-compliant product

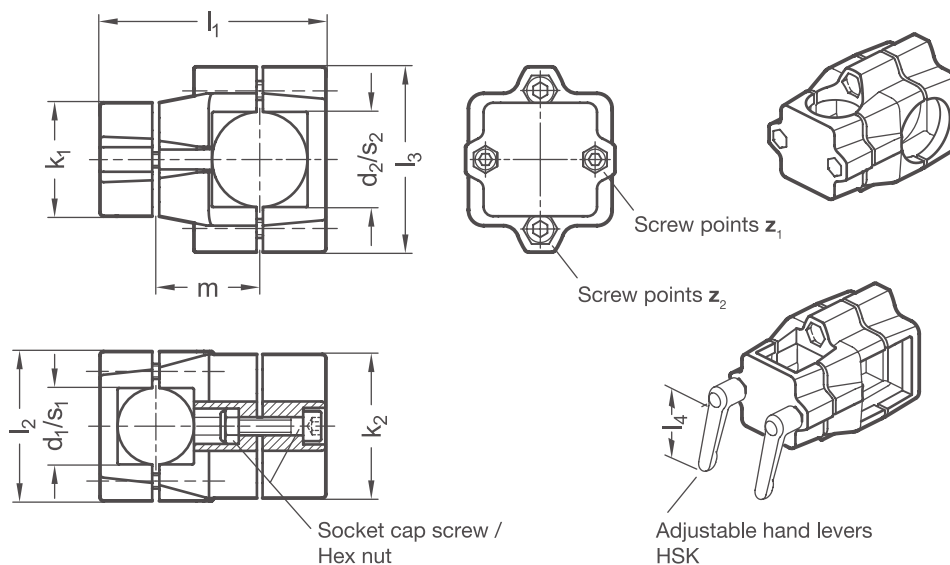

Clamping point 1		Clamping point 2		Clamping length k_1	Clamping length k_2	l_1	l_2	l_3	m	z_1	z_2	Accessories recom. hand lever	
Bore d_1	Square s_1	Bore d_2	Square s_2									HSK for z_1 lever length l_4	HSK for z_2 lever length l_4
B30	V30	B40	V40	60	76	120	79	98	55	M 8-50	M 10-50	78	92
B30	V30	B50	V50	60	76	120	79	98	55	M 8-50	M 10-50	78	92
B40	V40	B50	V50	60	76	120	79	98	55	M 8-50	M 10-50	78	92

Screw points

Z

1	Hex socket cap screw steel, zinc-plated DIN 912-8.8 and lock nut steel DIN 985-8, zinc-plated
2	Hex socket cap screw stainless steel DIN 912-A2-70 and lock nut stainless steel DIN 985-A2, glide coating

Surface

O

2	textured powder-coated, Black RAL 9005
8	blasted, matt

ORDER KEY

KMU - $d_1/s_1 - d_2/s_2 - k_1 - z - o$

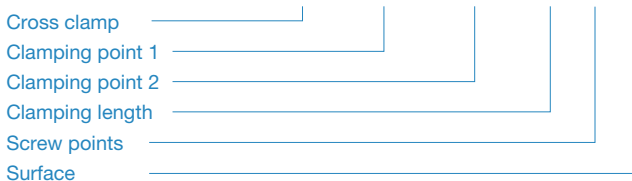

ACCESSORIES

– Adjustable hand levers **HSK** see page 168

ON REQUEST

- Clamping points with different diameters d_1 , d_2 , s_1 and s_2 or special diameters
- Screw points with hex head screws or mixed screw / adjustable hand lever elements
- Surface ball-burnished, anodized or powder-coated in other RAL colors